



Peri Pro⁺

FLOAT BASED CONDENSATE REMOVAL PUMP

The new Peri Pro⁺ pump offers outstanding reliability with an industry first 5 year warranty*. Built upon stepper motor technology and software control, this version offers smart pumping technology similar to the latest mini pumps, always minimising audible noise and tube wear.



15L/h max. flow



12m max. head (flow rate 15L/h)



1.12 kg

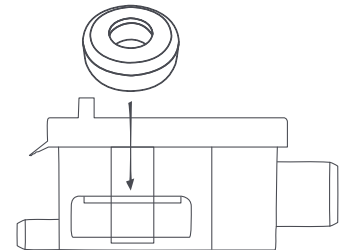
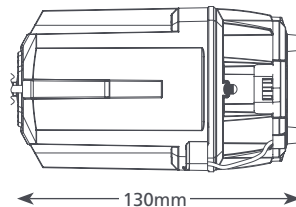
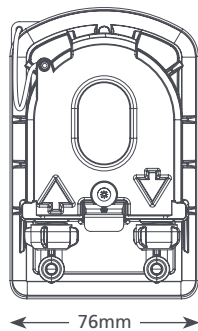
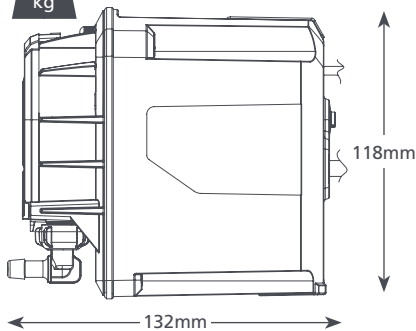

KEY FEATURES

- 5 year warranty*
- Smart features
- Flexible installation with outstanding lift
- Easy to install with Patented mounting technology

SUITABILITY

- High wall split systems; Ducted units; Floor standing & Chassis units
- ✓ **Perfect for...** hotel bedrooms and other remote install locations

PERI PRO ⁺ @ 110-230 VAC 50/60Hz	
Max. flow	15L/h @ 12m head
Max. head	12m
Max. suction lift	3m
dB(A) @ 1m	21
Power supply	110-230 VAC, 3A, 50/60Hz
Rated	Continuously
Class	II appliance <input type="checkbox"/>
Max. ambient temperature	40°C / 104°F
Inlet/outlet	6mm ID
IP Protection	IP24
Safety switch	5A NC relay
Self priming	✓

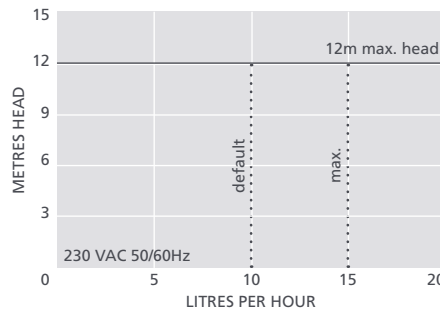

Peri Pro⁺ FP3391

SUGGESTED XTRA ACCESSORIES

Description	Part No.
Peri Spare Tube Kit	FP3394
1 Amp Fuse	FP2620
Tube To Soil Stack Adaptor	FP2038

Xtra For more installation accessories take a look at our Aspen Xtra range

IN THE BOX

- Peristaltic Float pump
- 3m Plug & play power / sensor cable
- Wall mounted bracket
- Fixing kit
- Installation manual

Download manual at aspenspumps.com

* excludes tube and subject to correct installation and operation